

SaniServ®



MADE IN USA

MODEL WB700-2



320
FROZEN
COCKTAILS/HR

AUTO-FILL SYSTEM FOR CONTINUOUS PRODUCT SUPPLY

The SaniServ® model WB700-2 Twin Head Frozen Beverage Freezer, with Remote Refrigeration and Auto-Fill, is designed to provide a high volume of frozen beverages through a continuous product source such as: "Bag in the Box" or pre-mixed product supply systems! The remote refrigeration system lowers the cost of indoor air-conditioning and reduce heat and noise levels.

**MODEL
WB700-2**

**AccuFreeze®
CONTROL**

Job: _____

Item No. _____



DESIGNED FOR HIGH VOLUME APPLICATIONS

20 Gallons per Hour - 5 Quart Evaporator Capacity

Use SaniServ® Model WB700-2 to Create



Dimensions: Width (19.1") Depth (26")
Height (25.5") Weight (185 lbs)

Electrical Requirements:

115/60/1 = 15 Amps

Serving Estimate:

Up to 320 Frozen Cocktails (160/side) / hr



About the WB700-2 Cooling Options



We reserve the right to change specifications and product designs without notice. Such revisions do not entitle the buyer to corresponding changes, improvements, additions, or replacements for previously purchased equipment.



✓ COUNTERTOP CONVENIENCE

The SaniServ® WB700-2, with Remote Refrigeration and Auto-Fill system, provides two flavors of high volume / high profit frozen beverages at the countertop, quietly and without the mess of product filling.

✓ EASY CLEANING AND OPERATION - *Fewer Parts = Simplified Cleaning*

SaniServ® equipment is designed and built with the fewest parts to be disassembled, cleaned and sanitized than any other machine in the industry. The state of the art solid-state AccuFreeze® control insures product consistency, worry-free operation and customer satisfaction.

✓ HIGH RETURN ON INVESTMENT - *Increased Profits*

SaniServ® machines combine efficiency with consistent product quality and fast, quiet operation while insuring customer satisfaction with high profit frozen beverages.

✓ QUALITY DESIGN - *Durability*

SaniServ® machines are built to achieve long and dependable life through simplicity of design. Every machine is shipped standard with a stainless steel exterior, durable steel interior frame construction, heavy-duty components and consistency systems.

MODEL WB700-2

AccuFreeze®
CONTROL

Minimum Wall Clearance
Both Sides and Back
6 inches (152 mm)

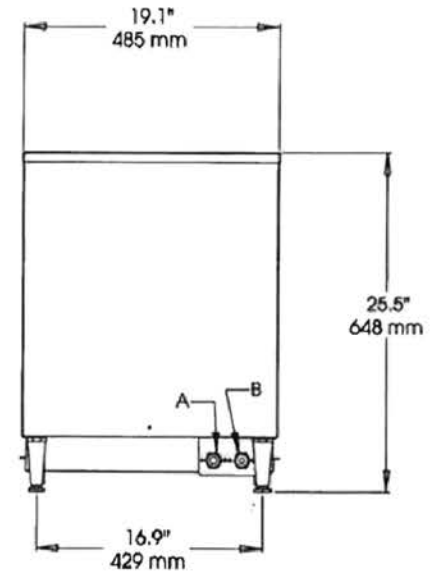
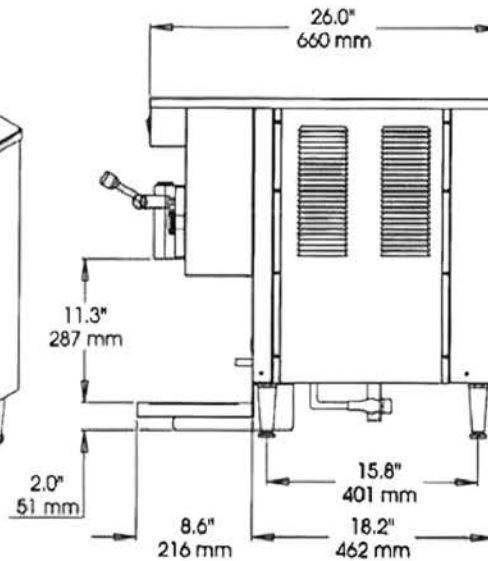
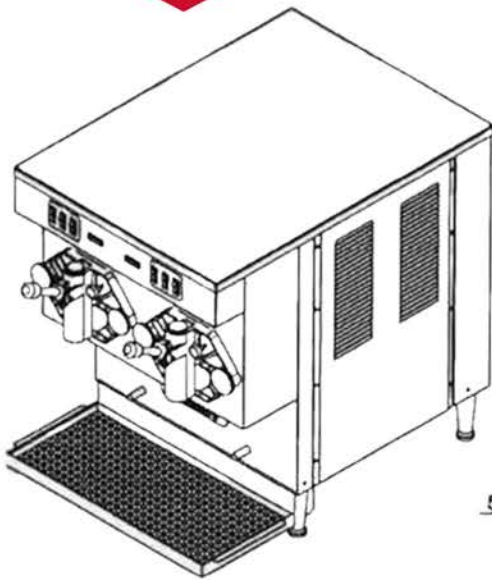

A 5/8" SUCTION LINE QUICK DISCONNECT
B 3/8" LIQUID LINE QUICK DISCONNECT

ELECTRICAL				WIDTH	HEIGHT	DEPTH	WEIGHT	VOLUME
VOLTS	Hz	Ph.	Amps	INCHES (MM)	INCHES (MM)	INCHES (MM)	LBS. (Kg)	CU FT. (cu. m.)
115	60	1	15	19.1 (660)	25.5 (648)	26 (660)	185 (85)	
Shipping Specifications				31.3 (800)	36.5 (927)	36.5 (927)	215 (98)	29.6 (.83)

SPECIFICATIONS

Dasher Motor:

1/4 HP Dasher

Refrigerator Type:

R404A

Listings:

UL, cUL, NSF

Additional Equipment

Required:

Requires a remote condensing unit (condenser & compressor) connected by two refrigeration lines.

FEATURES

Evaporator and Mix Reservoir

Capacity:

5 Quarts (4.7 liters)

Dasher:

Heavy-Duty Stainless Steel with low friction scraper blades.

Controls:

AccuFreeze® solid-state control for accurate product consistency.

Solid State Audio/Visual Mix Out System with Compressor Lockout

WARRANTY

Parts

1 year

Compressor

Not provided

Options:

Drink Spinner

Tune Up Kit

Machine Stand

Export Voltages