

SaniServ®



MADE IN USA

MODEL 601SAS



135
SHAKES/HR

GREAT FOR QUICK SERVICE RESTAURANTS & DRIVE-THRUS

The SaniServ® Model 601SAS Select-A-Shake freezer provides up to four flavors of uniform, smooth, high profit shakes! The 601SAS automatically mixes each shake uniformly to ensure a perfect milkshake in the flavor desired! Owners and operators will appreciate the machine's quick recovery time and ability to provide everyone's favorite flavor quickly even during peak operating periods! The 601SAS can satisfy everyone with their favorite flavor every time!

MODEL 601SAS

SELECT-A-SHAKE

Job: _____

Item No. _____



DESIGNED FOR HIGHER VOLUME APPLICATIONS

Three - 12 oz. Shakes per Minute - 20 Quart Capacity

Use SaniServ® Model 601SAS to Create



About the 601SAS Cooling Options



Dimensions:

Width (18.4") Depth (32.5")
Height (32") Weight (270 lbs)



Electrical Requirements:

208-230/60/1 = 20 Amps
208-230/60/3 = 15 Amps

Serving Estimate:

Up to 135 Milkshakes / hr

We reserve the right to change specifications and product designs without notice. Such revisions do not entitle the buyer to corresponding changes, improvements, additions, or replacements for previously purchased equipment.

✓ SPACE SAVING - *Small Footprint Design*

SaniServ® model 601SAS saves valuable floor space and turns the countertop into a real profit center by serving a large volume of high profit shake beverages in four flavors of your choice.

✓ EASY CLEANING AND OPERATION - *Fewer Parts = Simplified Cleaning*

SaniServ® equipment is designed and built with the fewest parts to be disassembled, cleaned and sanitized than any other machine in the industry.

✓ HIGH RETURN ON INVESTMENT - *Increased Profits*

SaniServ® machines combine efficiency with consistent product quality and fast, quiet operation while ensuring customer satisfaction with high profit ice cream or yogurt products.

✓ QUALITY DESIGN - *Durability*

SaniServ® machines are built to achieve long and dependable life through simplicity of design. Every machine is shipped standard with a stainless steel exterior, durable steel interior frame construction, heavy-duty components and consistency systems.

MODEL 601SAS

SELECT-A- SHAKE

Minimum Wall Clearance
Both Sides and Back
6 inches (152 mm)

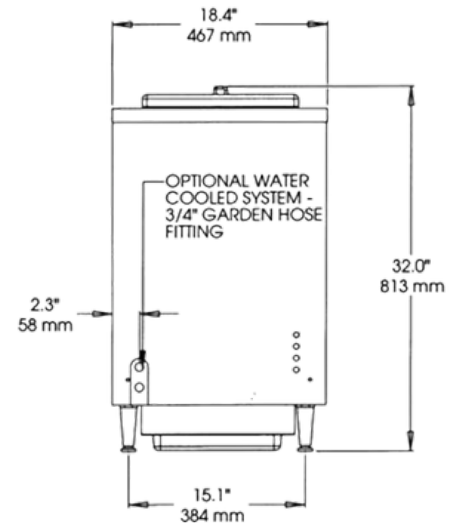
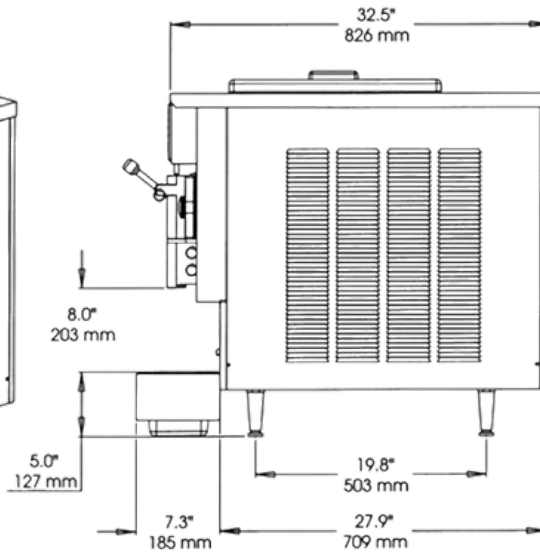
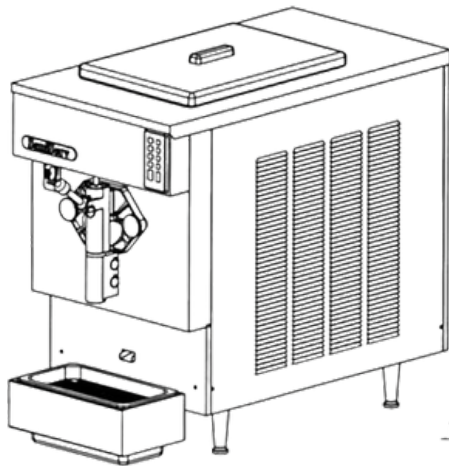

| ELECTRICAL | | | | WIDTH | HEIGHT | DEPTH | WEIGHT | VOLUME |
|-------------------------|----|-----|------|-------------|-------------|-------------|-----------|-----------------|
| VOLTS | Hz | Ph. | Amps | INCHES (MM) | INCHES (MM) | INCHES (MM) | LBS. (Kg) | CU FT. (cu. m.) |
| 208-230 | 60 | 1 | 20 | 18.4 (467) | 32 (813) | 32.5 (826) | 270 (122) | |
| 208-230 | 60 | 3 | 15 | | | | | |
| Shipping Specifications | | | | 24.5 (622) | 36 (914) | 40.5 (1028) | 300 (136) | 20.7 (.57) |

SPECIFICATIONS

Cooling System:

Air or Water

Dasher and Compressor

Motors:

1/2 HP Dasher

1 HP Compressor

Refrigerator Type:

R404A

Listings:

UL, cUL, NSF

This unit requires CO2 connection and a water line connection. The unit comes with 10' syrup line, (3) three gallon canisters, and one regulator.

FEATURES

Evaporator and Mix Reservoir

Capacity:

20 Quarts (18.9 liters)

Dasher:

Heavy-Duty Stainless Steel with low friction scraper blades.

Controls:

Automatic consistency controls for improved consistency.

Tamper Proof Automatic Visual Mix Out System

WARRANTY

Parts

Compressor 1 year
Evaporator 5 years

Options:

Tune Up Kit
Counter Top Mounting Pad
Machine Stand
Enclosed Machine Stand for Storage
Water Cooled - 3/4" Garden
Hose Fitting
Wash Out Kit - 3/8" Flare Fitting
Export Voltages